

Installation Instructions for: CONTOURED CORNER SEAT

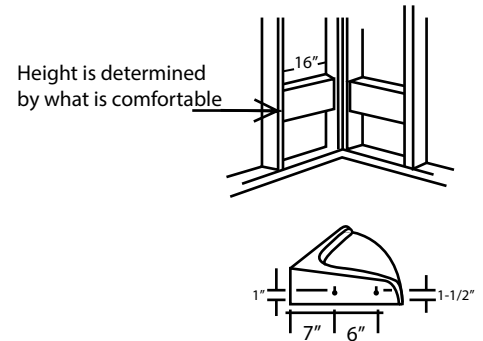

SITE PREPARATION: 1" x 8" backing boards are nailed in position between studs as shown. If access can be gained to the rear side of backing boards, plan seat installation using stainless steel bolts and washers. Wall anchors or lag screws may be used in inaccessible situations and steel based hardware will need to be rust proofed. If back is accessible use lagbolt and nut through wood.



Installation hardware package included.

Drill holes through each vertical mounting face of the seat in locations as shown. Hole size will be dependent on choice of mounting shown.

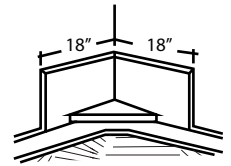

Place the support on top of the shower pan curb and push it into the corner. Locate the seat on top of the support. Mark holes to be drilled using pre-drilled holes in the seat as guided. Remove seat and drill holes in wall paneling. Wipe down wall and seat surfaces and locate seat as before. Secure the seat with mounting hardware. Apply silicone sealant to all exposed screws, bolts and washers. Remove support and apply silicone sealant along junction of seat and walls. Allow 24 hours curing time before actual use.

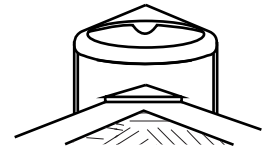

NOTE: BEFORE DRILLING HOLES IN WALL STRUCTURE, VERIFY THAT THERE ARE NO WATER PIPES OR ELECTRICAL WIRING CONCEALED BEHIND THE HOLE LOCATIONS.

